

Encimera de madera

Ref. 0317

600x500x16 mm

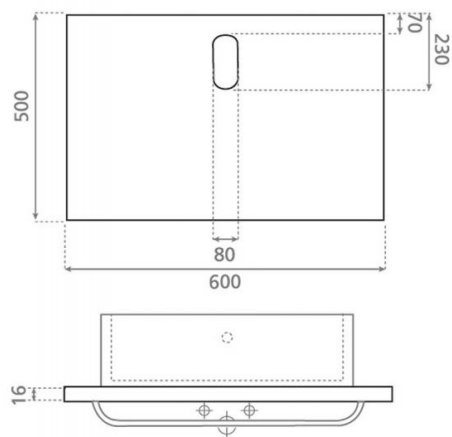

Características

Posibilidad de combinar con los soportes: ref. 00100 ref. 00101, ref 00102, ref 00109.

Acabados de madera WN (Wengue), CE (Cerezo).

